

Module Features

- Bluetooth system v2.0 + EDR
- Enhanced Data Rate (EDR) compliant with v2.0. of specification for both 2Mbps and 3Mbps modulation modes
- Class 2 Level Output Power Available
- UART Bypass Mode Support
- Scatternet Support
- Support of all Bluetooth packet types
- Support of low power modes: Park, Sniff and Hold
- UART, USB and PCM Interface Available
- Built-in Reference Clock : 26MHz
- RoHS Compliant

Applications

- Laptop and Desktop PCs
- Digital Camera and Printer
- Computer Accessories (compact Flash Cards, PCMCIA Cards, SD Cards and USB Dongles)
- Personal Digital Assistants (PDAs)

Features

- Size (18.0 X 14.0 X 2.2mm)
- Class2 Support
- Surface Mountable
- Support PCM interface for SCO
- Single 3.3V Power Supply

Overview

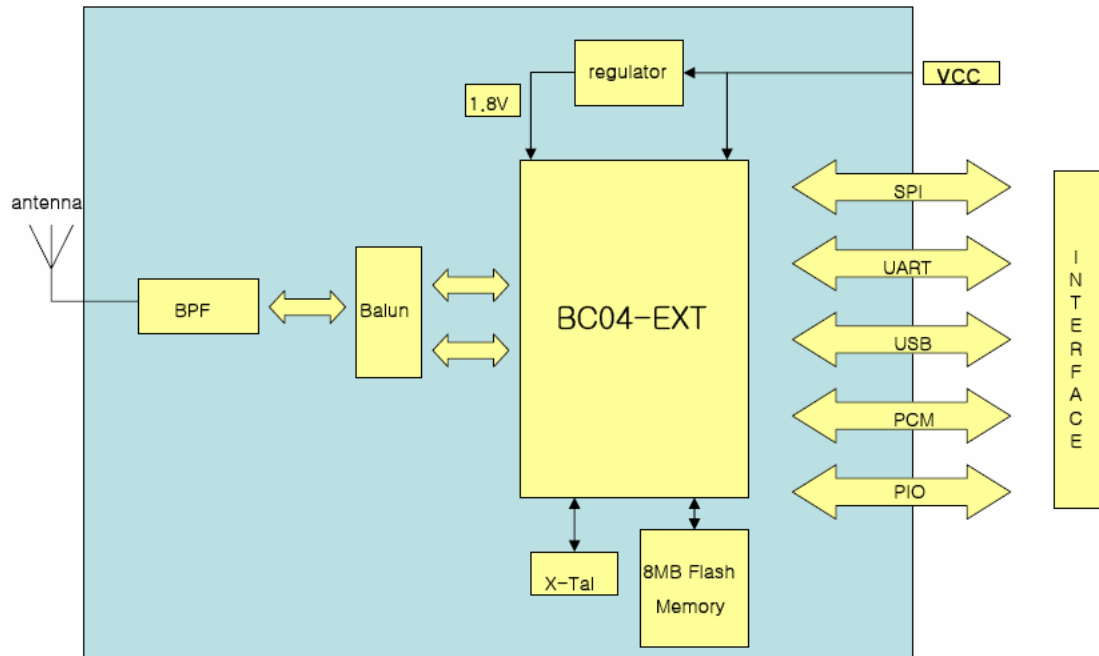

Electrical Characteristics

Absolute Maximum Ratings			
Parameter	Min	Max	Unit
Storage Temperature	-40	+ 85	°C
Supply Voltage	2.7	3.6	V _{cc}
Other Pin Voltage	V _{SS} -0.4	V _{CC} + 0.4	V
Recommended Operating Conditions			
Parameter	Min	Max	Unit
Temperature	-20	+ 70	°C
Supply Voltage	3.3V		V

RF specification

Transmitter Performance					
Parameter	Condition	Min	Typ	Max	Unit
Output Power	Normal/extreme test	-6	1	4	dBm
Power Density	Normal/extreme test	-	-	20	dBm
Power Control	Normal/extreme test				
Frequency Range	Normal/extreme test	2402	-	2480	MHz
20dB Bandwidth	Normal/extreme test	-	850	1000	KHz
Adjacent channel power	± 2 MHz	-	-	-20	dBm
	± 3 MHz	-	-	-40	dBm
	± 4 MHz	-	-	-40	dBm
Modulation Characteristics	$\Delta F1_{avg}$	140	-	175	KHz
	$\Delta F2_{max}$	115	-	-	KHz
	$\Delta F2_{avg}/\Delta F1_{avg}$	-	-	80	%
Initial Carrier Frequency Tolerance		-75	-	75	KHz
Carrier Frequency Drift	One slot Packet(DH1)	-25	-	25	KHz
	Three slot Packet(DH3)	-40	-	40	KHz
	Five slot Packet(DH5)	-40	-	40	KHz
Transceiver Performance					
Parameter	Condition	Min	Typ	Max	Unit
Out-of Band spurious Emissions	30MHz-1GHz	-	-	-36	dBm
	1GHz-12.75GHz	-	-	-30	dBm
	1.8GHz-5.3GHz	-	-	-47	dBm
	5.1GHz-5.3GHz	-	-	-47	dBm
Receiver Performance					
Parameter	Condition	Min	Typ	Max	Unit
Sensitivity level	Single slot packets	-70	-82	-	dBm
Sensitivity level	Multi slot packets	-70	-	-	dBm
C/I performance	C/I co-channel	-	9	11	dB
	C/I ₁ MHz(adjacent channel)		-2	0	dB
	C/I ₂ MHz(2nd Adjacent channel)		-34	-30	dB
	C/I _{≥ 3} MHz(3 rd adjacent channel)		-43	-40	dB
Blocking performance	30MHz-2000MHz	-10	-	-	dBm
	2000MHz-2400MHz	-27	-	-	dBm

	2500MHz-3000MHz	-27	-	-	dBm
	3000MHz-12.75MHz	-10	-	-	dBm
Intermodulation Performance	N=5	-39	-	-	dBm
Maximum Input Level		-20	-5	-	dBm

Pin Description

PIO No.	Pin Name	Description	Pad Type
1	RF_IN	RF connection to Antenna	Bi-direction
2	GND	Common Ground	Ground
3	PIO_4	Programmable input/output line	Bi-directional
4	PIO_3	Programmable input/output line	Bi-directional
5	PIO_2	Programmable input/output line	Bi-directional
6	PIO_5	Programmable input/output line	Bi-directional
7	SPI_CSB	Chip Select for Synchronous Serial interface active low	CMOS Input
8	GND	Common Ground	Ground
9	SPI_MOSI	Serial Peripheral Interface Data Output	Bi-direction
10	USB_DN	USB Data minus	Bi-direction
11	USB_DP	USB Data Plus with selectable internal 1.5K Ω Pull-up resistor	Bi-direction
12	PCM_CLK	Synchronous Data Clock	Bi-direction
13	PCM_OUT	Synchronous Data Output	CMOS Output
14	PCM_IN	Synchronous Data Input	CMOS Input
15	PCM_SYNC	Synchronous Data Sync	Bi-direction
16	V _{cc}	Power Supply	Power
17	SPI_MISO	Serial Peripheral Interface Data Input	CMOS Output
18	SPI_CLK	Serial Peripheral Interface Clock	CMOS Input
19	UART_CTS	UART request to clear to active low	CMOS Input
20	UART_RTS	UART request to send to active low	CMOS Output
21	UART_TX	UART Data Output	CMOS Output
22	UART_RX	UART Data Input	CMOS Input
23	GND	Common Ground	Ground
24	RESETB	Reset if low. Input debounced so must be	CMOS Input

		low for >5ms to cause a reset	
25	AIO_1	Programmable input/output line	Bi-directional
26	PIO_7	Programmable input/output line	Bi-directional
27	AIO_0	Programmable input/output line	Bi-directional
28	PIO_0	Programmable input/output line/RX EN	Bi-directional
29	PIO_1	Programmable input/output line/TX EN	Bi-directional
30	PIO_6	Programmable input/output line	Bi-directional

Pin Map (TOP View)



Dimension

